

Overview

Our mini lights have been designed to command immediate attention. The unique double fresnel lens has been optically engineered to maximize the light output. This is accomplished with a series of complementing fresnels that cause the dome to "fill" with light. This design feature increases the apparent AdaptaBeacon "on-time" improving viewer perception. Beam distance is increased through the addition of external fresnel lenses. Lenses are available in six colours: red; amber; blue; green; magenta; and clear.

Strobe

96C – Direct or Pipe Mount 120VAC

96C strobe lights have no moving parts and therefore are not subject to mechanical wear and are virtually immune to shock and vibration. The transistorized power supply and Xenon flash tube flashes a 360 degree beam of light of tremendous intensity through a shatter-resistant Lexan® optic lens.

They are ideally suited for installations where high ambient light levels make traditional rotating or flashing lights difficult to distinguish or where ambient noise makes audible signals difficult to hear.

98C Series – Direct or Pipe Mount

The DC version of the No. 96C Series strobe. For industrial applications, such as fork lifts, cranes and repair vehicles.

99C Series – Magnetic Mount - 12Vdc

A small, portable strobe with a magnetic base for temporary mounting on dash or vehicle roof. Comes with a 7-foot cord and cigarette lighter plug-in adapter.

Flashing Light

48CFIN Halogen / 48CFLED LED Direct or Pipe Mount

The mini flashing light is similar in design to the strobe except the light source is a low current halogen or LED lamp. The flash output is less intense than the strobe, however the longer "on" time of the flash makes this unit suitable for many industrial applications.

Steady Light

48CSIN Halogen / 48CSLED LED Direct or Pipe Mount

The mini steady light provides a constant visual signal. It is ideal for start/stop functions, on/off processes or continuous duty visual signalling applications.

Standard Features

- NEMA 4X enclosure
- AC or DC models
- All AC models CSA certified
- Direct or pipe mounting
- Suitable for indoor or outdoor installation (-35 to +66°C)
- Optically designed Fresnel lens

Applications

AdaptaBeacon lights are designed for indoor or outdoor installation.

While strobe, flashing and steady lights may be mounted on any plane; vertical installation is generally most suitable as this assures maximum beam width projection. For weatherproof mounting the lights shall be pipe mounted with the lens facing up.

Adaptabeacon® Mini Strobe, Steady On & Flashing Lights

48CS and 48CF, 98C and 99C



CONTINUES...

...CONTINUED

Ordering Information

Description	Cat. No.	Nom. Amp Rating	Voltage	Replacement Lens	Mounting
Steady On Light	48CSIN(+)-N5-25WH	0.2	120VAC	96L(+)	Mounting direct or 1/2" NPT conduit mounting.
	48CSIN(+)-G5-20WH	0.80	24VAC	96L(+)	
	48CSIN(+)-E1	1.0	12Vdc	96L(+)	
	48CSIN(+)-G1-20WH	0.80	24Vdc	96L(+)	
Steady On LED	48CSLED(+)-G1	0.062	24Vdc	96L(+)	
	48CSLED(+)-N5	0.022	120VAC	96L(+)	
Flashing Light Flash rate: 65 FPM	48CFIN(+)-N5-25WH	0.2	120VAC	96L(+)	
	48CFIN(+)-G5-20WH	0.80	24VAC	96L(+)	
	48CFIN(+)-E1	1.0	12Vdc	96L(+)	
	48CFIN(+)-G1-20WH	0.80	24Vdc	96L(+)	
Flashing LED Light Flash rate: 65 FPM	48CFLED(+)-G1	0.062	24Vdc	96L(+)	
	48CFLED(+)-N5	0.022	120VAC	96L(+)	
Strobe Light Flash rate: 65 FPM	96C(+)-N5-1	0.1	120VAC	96L(+)	
Strobe Light Flash rate: 65 FPM	98C(+)-E1-1	0.5	12Vdc	96L(+)	
Strobe Light Flash rate: 65 FPM	98C(+)-G1-1	0.3	24Vdc	96L(+)	
Portable Strobe Light Flash rate: 65 FPM	99C(+)-E1-1	0.5	12Vdc	96L(+)	Magnetic Mount. 7 ft. cord with cigarette lighter adapter.

(+) Specify color: R=Red, A=Amber, B=Blue, G=Green, C=Clear, M=Magenta
Note: 48SLED and 48FLED models available in Red, Amber, Blue and Green only

Installation and Mounting

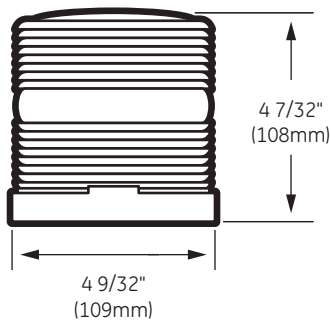

96C & 98C Series
Strobe Light

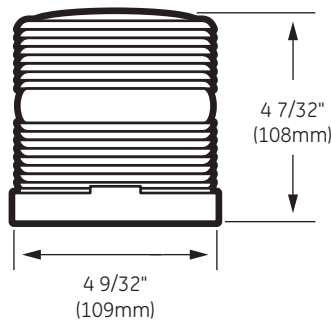

48CSIN
48CSLED
48CFIN
48CFLED

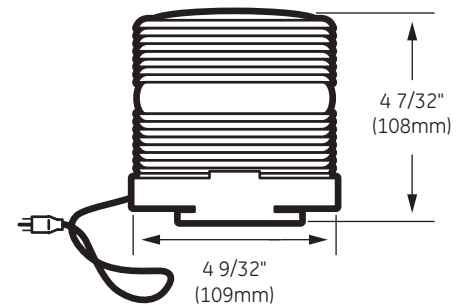

99C Series
Strobe Light
Magnetic Mounting

