

Overview

Low-current, extremely high decibel, high performance signalling device. Horn and siren models available. Horn may be coded or used as continuous alarm.

All solid-state (no contacts to wear out). Eliminates excessive start-up current. High decibel sound output (105 to 109 dB at 10 feet). Metallic grey finish.

Applications

Use explosionproof model in mines, granaries, flour mills, tankers, refineries, laboratories and other hazardous locations.

Horn:

For timing, scheduling, paging, alarms or coded signals. Predominant frequency is 1.1 KHz.

Siren:

For use where standard horns or bells are not satisfactory. Rises and falls from 300-3000 Hz every 3 seconds. Not adaptable for coding. Particularly suited to areas of high noise level.

5524 & 5525 Series:

- **CSA approved for:**
Class I, Division 1, Groups C and D, and
Class II - Division 1, Group E, F and G applications.

Each unit fitted with sealed, threaded 3/4" pipe nipple and 30" wire lead for connection. Explosionproof models are not available weatherproof.

Standard Features

- AC and DC types
- Explosionproof
- FM approved/Lloyd's listed
- CSA Certified
- Electronic tone generator

Ordering Information

Cat. No.	Volts	Amps	VA	dB@10' (3m)
5524-AQ	24VAC*	0.85	21	109 (Horn only)
	24Vdc	0.35	8.4	109 (Horn only)
5524-P1	125Vdc	0.1	12	109 (Horn only)
5524-N5	120VAC*	0.28	33	109 (Horn only)
5525-AQ	24VAC*	0.85	21	105 (Siren only)
	24Vdc	0.35	8.4	105 (Siren only)
5525-P1	125Vdc	0.1	12	105 (Siren only)
5525-N5	120VAC*	0.28	33	105 (Siren only)

*50/60 Hz

Installation and Mounting

Mounts on any solid surface using three bolts. May be swivelled through 180 degrees, vertically or horizontally, depending on mounting of bracket. Flange bolts are epoxy sealed in accordance with CSA requirements to prevent disassembly or tampering.

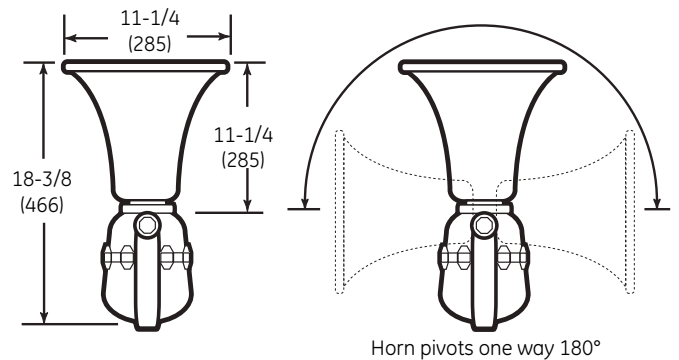

Duotronic Explosionproof Horn/Siren

